



PARTNERSKA BROŠURA

2025



# FORMULA STUDENT TIM DRUMSKA STRELA 2025



fsra.stt.org.rs



@roadarrowteam



Road Arrow



DrumskaStrelaFS



Studentska Tehnička Takmičenja, Student Technical Tournaments,  
Studentski trg 1, 11000 Beograd;  
www.fsra.stt.org.rs, formula.student@stt.org.rs;  
Matični broj: 28032463, PIB: 106916946;  
Brojevi računa: dinarski 160-0000000399026-75,  
devizni IBAN: RS35160005080003758960

## VOĐA TIMA

Boško Bajić  
bosko.bajic.fsra2022@gmail.com  
+381(0)638382837



Drumska Strela je prvi srpski Formula Student tim.

# FORMULA STUDENT

Formula student je najprestižnije svetsko inženjersko takmičenje za studente. Ovo takmičenje nudi jedinstvene načine za testiranje njihovog teorijskog znanja kroz rešavanje realnih praktičnih problema.

Uspeh tima ocenjuju iskusni inženjeri iz sveta auto-indrustrije i auto-moto sporta, kroz različite discipline koje uključuju: inženjerski dizajn, analizu troškova, bizis plan i performanse vozila na stazi.

Cilj takmičenja jeste edukacija i razvoj studenata kroz projektovanje i izradu trkačkog vozila.



# STRUKTURA TIMA



Tim se sastoji iz 7 podtimova:

Šasija i ergonomija

Aerodinamika

Dinamika vozila

Prenos snage

High voltage

Low voltage

Marketing i sponzorstva

2010

Osnovano udruženje STT i prvi srpski Formula Student tim.

2013

Izrada novog vozila i osvajanje 10. mesta na takmičenju u Italiji.



2016

Novo vozilo i prva izrada delova od ugljeničnih vlakana.



2019

Tim nastupa na 3 velika takmičenja: Velika Britanija, Holandija i Mađarska.



2022

Izrađen prvi električni bolid u Srbiji! Kvalifikacije na 4 prestižna takmičenja.



2011

Prvo takmičenje i nastup sa idejnim konceptom. Osvojeno 3. mesto u Klasi II na legendarnoj stazi Silverston u Velikoj Britaniji.

2014

Novo vozilo sa prvim aero-paketom i varijabilnim usisom.

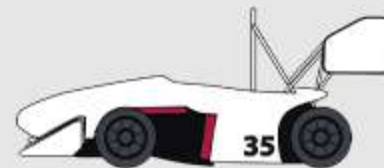

2017

Tim nastupa po prvi put na legendarnoj stazi Hockenheim.



2020

Pauza u takmičenjima usled pandemije Kovid-19, ali nastavljeno projektovanje vozila.

2012

Tim izrađuje prvo vozilo i nastupa na 2 takmičenja.

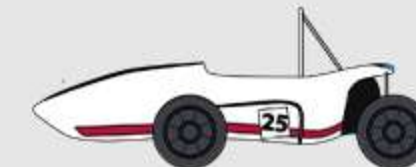

2015

Redizajn vozila, novi aero-paket, 4. mesto na trci izdržljivosti.

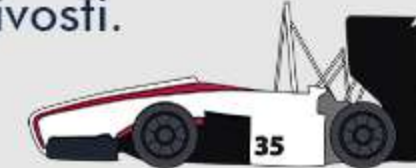

2018

Napravljeno najbrže i najpouzdanije vozilo u istoriji tima.



2021

Nastup na 3 velika takmičenja i osvojena 2. nagrada u Hrvatskoj.



2025 uskoro...

---

# TEHNIČKE SPECIFIKACIJE VOZILA

Tip šasije  
Materijal

monokok  
karbonska vlakna,  
aluminijumska ispuna

Ubrzanje 0-100 km/h  
Maksimalna brzina  
Maks. obrtni moment

4.4 sekunde  
118 km/h  
1028 Nm

Aktivna aerofinamika DRS  
Ventrujivevi kanali na podu  
Dva planetarna prenosnika  
Pogon na zadnjim točkovima

Torque vectoring system  
Napon baterije 330 V  
Simetrična šasija  
Litijum-jonske baterije

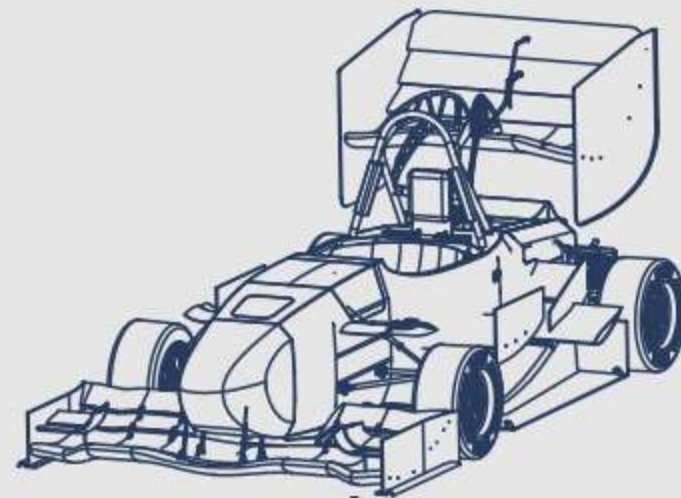
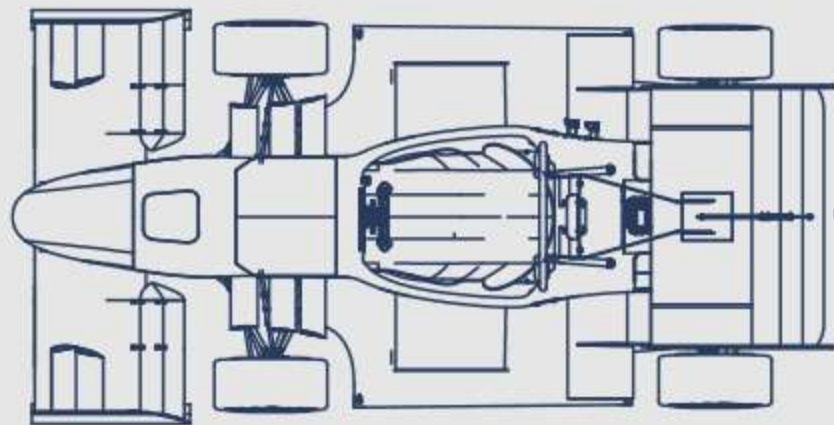
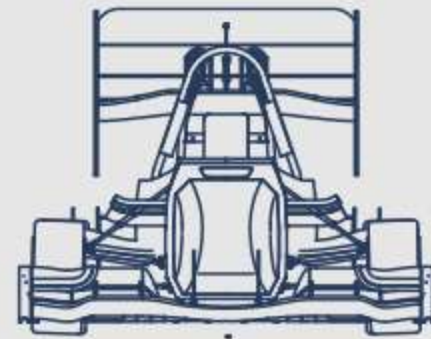
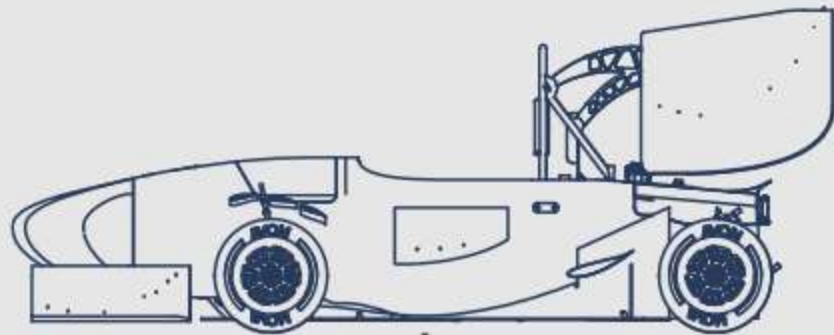



## SPONZORSKI PAKETI

	PRIJATELJ	BRONZANI	SREBRNI	ZLATNI	PLATINUM	GENERALNI
Logo i hyperlink kompanije na oficijalnom veb-sajtu projekta	+	+	+	+	+	+
Prisustvo predstavnika kompanije na specijalnim događajima	+	+	+	+	+	+
Promocija na društvenim mrežama	<b>1</b>	<b>2</b>	<b>3</b>	<b>4</b>	<b>5</b>	<b>5</b>
Logo na reklamnom materijalu	+	+	+	+	+	+
Logo na formuli		<b>S</b>	<b>M</b>	<b>L</b>	<b>XL</b>	<b>XXL</b>
Logo na timskoj odeći			<b>S</b>	<b>M</b>	<b>L</b>	<b>XL</b>
Mogućnost deljenja objava kompanije				+	+	+
Prisustvo vozila i članova na događajima kompanije					+	+
Vozilo u bojama kompanije						+





Univerzitet u Beogradu  
Tehnološko-metalurški fakultet



Mercedes-Benz



RIVIAN





## DRUMSKA STRELA NA DOGAĐAJIMA

Formula Student tim **"Drumska Strela"** je redovan gost na svim većim manifestacijama koje se tiču auto-industrije, obrazovanja, promocije nauke i tehnike. Neke od njih su **Sajam automobila, EV Days, Sajam tehnike**, itd. Takođe, naš tim pridaje veliki značaj saradnji sa stručnjacima iz industrije koje naši članovi imaju priliku da sretnu kroz organizaciju poseta u kompanijama naših partnera. Ovakvi vidovi saradnje su od izuzetnog značaja našem timu i težimo da ih negujemo još dugi niz godina.

Tim **"Drumska Strela"** i **udruženje STT** su nedavno pokrenuli projekat **"Industrial Talk"** u saradnji sa **Mašinskim fakultetom, Studentskim centrom izvrsnosti** i renomiranim kompanijama auto-industrije. Projekat je okupio više od 400 studenata na prve dve prezentacije. Uspeh se ogleda u prilagođavanju programa svakoj kompaniji, omogućavajući realističan prikaz radnih uslova. Fokus je na komunikaciji, pitanjima i interakciji, izbegavajući dugačka predavanja. Pozitivne reakcije i veliki broj prisutnih potvrđuju efikasnost ovog pristupa. Zahvaljujemo kompanijama **Brose DOO Pančevo** i **Robert Bosch DOO Beograd** na podršci.

## FORMULA STUDENT I MEDIJI



Univezitet u Beogradu protiv  
najboljim svetskim studentskim  
timovima

ПОЛИТИКА

Tim "Drumska Strela" ponos  
Mašinskog fakulteta



Studenti napravili prvi električni  
bolid u Srbiji



Ponos i budućnost Srbije



Studenti predstavili prvu srpsku  
električnu formulu



Tim "Drumska Strela" dobio  
priznanje "Korak u budućnost"



Električna snaga, trkačka strast.